

INSTRUCTION MANUAL

BatteryMINDer® 2000 Series

Charger / Maintainer / Desulfator



INCLUDES:

- 2' Fused Ring Terminal Cord Set with Quick Connector
- 2' Battery Clip Cord Set with Quick Connector
- Ambient Temperature Sensor

VDC Electronics, Inc.
147D Woodbury Rd.
Huntington, NY 11743
www.BatteryMINDers.com
techsupport@vdcelectronics.com

**READ AND SAVE THESE
INSTRUCTIONS**

TABLE OF CONTENTS

Safety Instructions 3 - 7

Warning - Risk of Explosive Gases 4

Personal Precautions 4

Preparing to Charge 5

Charger Location 5

DC Connection Precautions 6

Reduce Risk of a Spark Near Battery 6, 7

Operation Instructions 8 - 14

Indicator Light Table 8, 9

Quick Connect Instructions 9

Charging Stages 9

Indicator Light Details 10

Temperature Compensation 11

Voltage Table 12

Specifications Table 12

Maintaining Multiple Batteries 13

Battery Configurations 13

Charging Profile 14

Repair or Replacement 15

Warranty and Registration 16

**Underwriters Laboratories (UL)
REQUIRED IMPORTANT SAFETY INSTRUCTIONS for
the BATTERYMINDER 2000 SERIES**

WARNING

**TO REDUCE THE RISK OF FIRE, ELECTRIC SHOCK,
OR INJURY TO PERSON, OBSERVE THE
FOLLOWING:**

1. SAVE THESE INSTRUCTIONS

This manual contains important safety and operating instructions for BatteryMINDER 2000 Series.

2. Do not expose charger to rain or snow.
3. Use of an attachment not recommended or sold by VDC Electronics may result in a risk of fire, electric shock, or injury to persons.
4. To reduce risk of damage to electric plug and cord, pull by plug rather than cord when disconnecting charger.
5. An extension cord should not be used unless absolutely necessary. Use of improper extension cord could result in a risk of fire and electric shock. If an extension cord must be used, make sure:
 - a) That pins on plug of extension cord are the same number, size, and shape as those of plug on charger;
 - b) That extension cord is properly wired and in good electrical condition; and
 - c) That wire size is large enough for ac ampere rating of charger as specified in Table below.

Recommended minimum AWG size for extension cords for battery chargers					
AC Input Rating, amperes^a		AWG Size of Cord			
Equal To or Greater Than	But Less Than	Length of Cord, feet (m)			
		25 (7.6)	50 (15.2)	100 (30.5)	150 (45.6)
0	2	18	18	18	16
<small>^aIf the input rating of a charger is given in watts rather than in amperes, the corresponding ampere rating is to be determined by dividing the wattage rating by the voltage rating - for example: 1250 watts/125 volts = 10 amperes</small>					

6. Do not operate charger with damaged cord or plug – replace the cord or plug immediately.
7. Do not operate charger if it has received a sharp blow, been dropped, or otherwise damaged in any way; call **VDC Electronics Tech Support Dept. 800.379.5579 x206 (ET)** for advice.
8. Do not disassemble charger; call **VDC Electronics Tech Support Dept. 800.379.5579 x206 (ET)** for advice when service or repair is required. Incorrect reassembly may result in a risk of electric shock or fire.
9. To reduce risk of electric shock, unplug charger from outlet before attempting any maintenance or cleaning. Turning off controls will not reduce this risk.
- 10. WARNING – RISK OF EXPLOSIVE GASES**
 - a) **WORKING IN VICINITY OF A LEAD-ACID BATTERY IS DANGEROUS. BATTERIES GENERATE EXPLOSIVE GASES DURING NORMAL BATTERY OPERATION. FOR THIS REASON, IT IS OF UTMOST IMPORTANCE THAT YOU FOLLOW THE INSTRUCTIONS EACH TIME YOU USE THE CHARGER.**
 - b) To reduce risk of battery explosion, follow these instructions and those published by manufacturer of any equipment you intend to use in vicinity of battery. Review cautionary marking on these products and on engine.
- 11. PERSONAL PRECAUTIONS**
 - a) Consider having someone close enough by to come to your aid when you work near a lead-acid battery.
 - b) Have plenty of fresh water and soap nearby in case battery acid contacts skin, clothing, or eyes.
 - c) Wear complete eye protection and clothing protection. Avoid touching eyes while working near battery.
 - d) If battery acid contacts skin or clothing, wash immediately with soap and water. If acid enters eye, immediately flood eye with running cold water for at least 10 minutes and get medical attention immediately.
 - e) NEVER smoke or allow a spark or flame in vicinity of battery or engine.
 - f) Be extra cautious to reduce risk of dropping a metal tool onto battery. It might spark or short-circuit battery or other electrical

part that may cause explosion.

g) Remove personal metal items such as rings, bracelets, necklaces, and watches when working with a lead-acid battery. A lead-acid battery can produce a short-circuit current high enough to weld a ring or the like to metal, causing a severe burn.

h) Use charger for charging a LEAD-ACID battery only. It is not intended to supply power to a low voltage electrical system other than in a starter-motor application. Do not use battery charger for charging dry-cell batteries that are commonly used with home appliances. These batteries may burst and cause injury to persons and damage to property.

i) NEVER charge a frozen battery or a battery at a temperature above 123° F.

12. PREPARING TO CHARGE

a) If necessary to remove battery from vehicle to charge, always remove grounded terminal from battery first. Make sure all accessories in the vehicle are off, so as not to cause an arc.

b) Be sure area around battery is well ventilated while battery is being charged.

c) Clean battery terminals. Be careful to keep corrosion from coming in contact with eyes.

d) Add distilled water in each cell until battery acid reaches level specified by battery manufacturer. Do not overfill. For a battery without removable cell caps, such as valve regulated lead acid batteries, carefully follow manufacturer's recharging instructions.

e) Study all battery manufacturer's specific precautions while charging and recommended rates of charge.

f) Determine voltage of battery by referring to car owner's manual and make sure it matches output rating of battery charger.

13. CHARGER LOCATION

a) Locate charger as far away from battery as DC cables permit.

b) Never place charger directly above battery being charged; gases from battery will corrode and damage charger.

c) Never allow battery acid to drip on charger when reading electrolyte specific gravity or filling battery.

d) Do not operate charger in a closed-in area or restrict ventilation in any way.

e) Do not set a battery on top of charger.

14. DC CONNECTION PRECAUTIONS

a) Connect and disconnect dc output clips only after setting any charger switches to "off" position and removing ac cord from electric outlet. Never allow clips to touch each other.

b) Attach clips to battery and chassis as indicated in 15(e), 15(f), and 16(b) through 16(d).

15. FOLLOW THESE STEPS WHEN BATTERY IS INSTALLED IN VEHICLE. A SPARK NEAR BATTERY MAY CAUSE BATTERY EXPLOSION.

TO REDUCE RISK OF A SPARK NEAR BATTERY:

a) Position ac and dc cords to reduce risk of damage by hood, door, or moving engine part.

b) Stay clear of fan blades, belts, pulleys, and other parts that can cause injury to persons.

c) Check polarity of battery posts. POSITIVE (POS, P, +) battery post usually has larger diameter than NEGATIVE (NEG, N, -) post.

d) Determine which post of battery is grounded (connected) to the chassis. If negative post is grounded to chassis (as in most vehicles), see (e). If positive post is grounded to the chassis, see (f).

e) For negative-grounded vehicle, connect POSITIVE (**RED**) clip from battery charger to POSITIVE (POS, P, +) ungrounded post of battery. Connect NEGATIVE (**BLACK**) clip to vehicle chassis or engine block away from battery. Do not connect clip to carburetor, fuel lines, or sheet-metal body parts. Connect to a heavy gage metal part of the frame or engine block.

f) For positive-grounded vehicle, connect NEGATIVE (**BLACK**) clip from battery charger to NEGATIVE (NEG, N, -) ungrounded post of battery. Connect POSITIVE (**RED**) clip to vehicle chassis or engine block away from battery. Do not connect clip to carburetor, fuel lines, or sheet-metal body parts. Connect to a heavy gage metal part of the frame or engine block.

g) When disconnecting charger, turn switches to off, disconnect AC cord, remove clip from vehicle chassis, and then remove clip from battery terminal.

h) See operating instructions for length of charge information.

16. FOLLOW THESE STEPS WHEN BATTERY IS OUTSIDE VEHICLE. A SPARK NEAR THE BATTERY MAY CAUSE BATTERY EXPLOSION.

TO REDUCE RISK OF A SPARK NEAR BATTERY:

a) Check polarity of battery posts. POSITIVE (POS, P, +) battery post usually has a larger diameter than NEGATIVE (NEG, N, -) post.

b) Attach at least a 24-inch-long 6-gauge (AWG) insulated battery cable to NEGATIVE (NEG, N, -) battery post.

c) Connect POSITIVE (**RED**) charger clip to POSITIVE (POS, P, +) post of battery.

d) Position yourself and free end of cable as far away from battery as possible – then connect NEGATIVE (**BLACK**) charger clip to free end of cable.

e) Do not face battery when making final connection.

f) When disconnecting charger, always do so in reverse sequence of connecting procedure and break first connection while as far away from battery as practical.



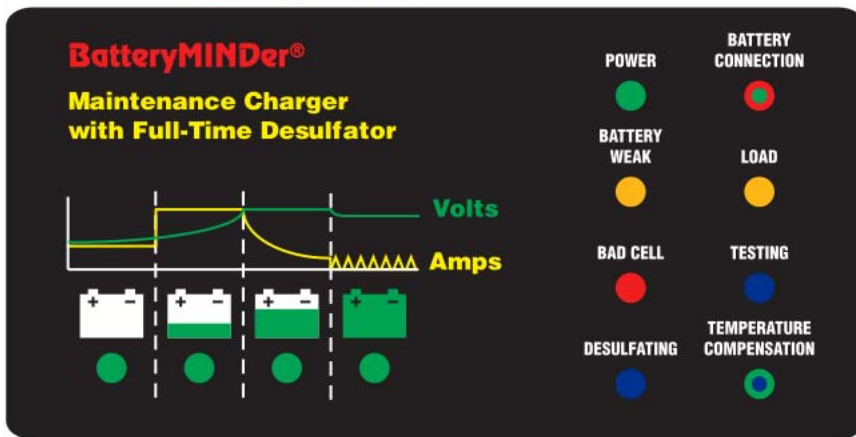

g) A marine (boat) battery must be removed and charged on shore. To charge it on board requires equipment specially designed for marine use.

BatteryMINDER 2000 Series Label



Indicator Light Table

Indicator Light Table		
●	Power	A/C Power Connected
●	Battery Connection	Battery Connected Correctly
●	Battery Connection	Battery Connection Reversed
●	Battery Weak	<ul style="list-style-type: none"> Battery Required Soft Start Battery Tests Under 12.5V
●	Load	Battery under load and cannot maintain FV* (See Voltage Table)
●	Bad Cell	Battery under 11.5V after Battery Test
●	Testing	Battery is being Tested
●	Desulfating	Battery is being Desulfated
●	Temperature Compensation	Temperature Over 27°C/80°F
●	Temperature Compensation	Temperature Under 21°C/70°F

	Load Light Off		Load Light ●	
	Soft Start	0.5 A	Float (Battery < 11V)	2.0 A
	Constant Current	2.0 A	Float (Battery < 12V)	2.0 A
	Constant Voltage	CV* (See Voltage Table)	Float (Battery < 13V)	2.0 A
	Float (Charge Complete)	FV* (See Voltage Table)	Float (Battery > 13V)	2.0 A

Quick Connect Instructions

1. Place the Positive (**RED**) clip on the positive battery terminal.
2. Place the Negative (**Black**) clip on the negative battery terminal.
3. Plug in the BatteryMINDER.
4. Power and Battery Connection light should be **GREEN**. Indicator will come on showing state of battery charge and present charging stage.

Charging Stages



- **Soft Start** is used if a battery's voltage is under 10.5V when charging begins. It uses a low constant current to slowly bring up voltage. This prepares a weak or neglected battery for the Constant Current stage.
- **Constant Current** (sometimes called Bulk) is the main charging stage. The charger puts out a constant current of 2A, its full power. Battery voltage rises until the battery reaches the optimal charging voltage CV* (See Voltage Table).
- **Constant Voltage** (sometimes called Absorption) is the second charging stage. The charger regulates the current given to the battery to maintain a constant voltage CV* (See Voltage Table). As the battery nears a full charge, the current needed to maintain this voltage decreases. Once the current falls below 0.5A (0.1A for 2012-AGM) the stage is complete.
- **Battery Test** is administered by reading your battery voltage while resting the battery for 10 minutes. A voltage of under 12.5V indicates a weak battery, under 11.5V indicates a shorted cell. The battery is tested at completion of the **Constant Voltage** stage, and every 12 hours while in **Float**

- **Float** (sometimes called Maintenance) is the charger's long term stage. The charger can and should be left connected indefinitely. This will keep the battery fully charged ensuring no sulfate can form. The charger maintains float voltage FV* (See Voltage Table) using very little power as it actively monitors the battery and adjusts its output several times a second.

Indicator Light Details

- **Power** light is **GREEN** anytime the charger is plugged into AC Power.
- **Battery Connection** light is **GREEN** when the unit is correctly connected to a battery. If the Battery Connection light is **RED** the polarity is reversed and the positive and negative terminals need to be switched. If the light remains **RED** after switching the connections, there is a short circuit.
- **Battery Weak** light is **AMBER** if the Soft Start mode is used or the battery fails a Battery Test. The indicator will stay on until the battery passes a Battery Test.

A neglected battery can take over 2 weeks of desulfation to correct. If after 2 weeks it still reads as a Weak Battery, there is likely internal physical damage.

- **Load** light is **AMBER** if the charger is in Float and outputting 2A. This indicates a drain on the battery or a large battery that was not charged within the time limits. If possible remove any loads. When this light is on, the battery charge level lights correspond only to battery voltage, not charging stages (see Load Light ● Table, Page 9).
- **Bad Cell** light flashes **RED** if the charger has not completed the Constant Current stage in 20 hours and battery voltage is under 11.5V ( Flashing), or if the battery is under 11.5V after a Battery Test ( Flashing).

The charger shuts off output to avoid any damage to your battery. Loads or banks of batteries may trigger this mode if they are too large for this charger. Remove any loads and charge batteries individually.

- **Testing** light flashes **BLUE** when the unit is performing a **Battery Test** (see **Charging Stages**).

- **Desulfation** light flashes **BLUE** any time the unit is desulfating. The BatteryMINDER desulfates any time it is outputting current.
- **Temperature Compensation** light is **GREEN** if the temperature is over 27°C/80°F, **BLUE** if the temperature is under 21°C/70°F. BatteryMINDER Model 2012 includes an ambient temperature sensor which allows it to vary the output voltage as necessary to properly charge your battery (-0.025 V/°C). Batteries charged at higher temperatures without compensation will overcharge and may outgas. Batteries charged at lower temperatures without compensation will undercharge allowing sulfation to build, possibly leading to the battery freezing. By using temperature compensation, the BatteryMINDER ensures your battery will never over or under charge, even in extreme conditions.

Temperature	Compensation
50°C / 122°F	-0.625 V
45°C / 113°F	-0.500 V
40°C / 104°F	-0.375 V
35°C / 95°F	-0.250 V
30°C / 86°F	-0.125 V
25°C / 77°F	0.000 V
20°C / 68°F	+0.125 V
15°C / 59°F	+0.250 V
10°C / 50°F	+0.375 V
5°C / 41°F	+0.500 V
0°C / 32°F	+0.625 V
-5°C / 23°F	+0.750 V
-10°C / 14°F	+1.000 V
-15°C / 5°F	+1.125 V
-20°C / -4°F	+1.250 V

Consider using accessory ABS-248 “At the Battery Sensor” for more accurate temperature compensation. It is highly recommended if your battery is located in a different environment or compartment than your charger.

Voltage Table

*CV : Voltage during the Constant Voltage stage

*FV : Voltage during the Float stage.

Model	Battery Types	*CV	*FV
2012	Standard (Flooded)	14.4V	13.4V
2012-GEL	Gel	14.1V	13.05V
2012-AGM	AGM	14.7V	13.6V
2012-CAL	Calcium	15.16V	13.5V

Specifications Table

Input	100-240 VAC, 50/60 Hz, 0.65A
Output	2ADC \pm 0.2A
Float Current	1mA - 2000mA
Size	5.69" L x 4.06" W x 2.13" H
Weight	1.56 lbs.
Operating Temperature	-20°C / -4°F to 40°C / 104°F
Water Resistance	IP65

MAINTAINING MULTIPLE BATTERIES

To properly charge or maintain multiple batteries they should all be the same type (gel, flooded or AGM) and condition. It is OK to mix deep cycle and starter. Charge each battery individually before connecting together. **Never connect batteries at different states of charge. The charged battery will rapidly transfer energy to the discharged battery possibly causing catastrophic failure.** Once the batteries are charged, use 18 gauge or greater wire to connect the batteries.

If connecting multiple batteries of the same voltage, wire them in parallel (BatteryMINDer positive to positive A to positive B, BatteryMINDer negative to negative A to negative B). This is the same type of connection you would use when jumping a car (in fact, jumper cables are great for this).

If connecting 2 batteries of half your unit's voltage (example: 6V batteries on a 12V unit), wire them in series (BatteryMINDer positive to positive A, negative A to positive B, negative B to BatteryMINDer negative). When wired in series they act as one large system at the combined voltage (example: 6V + 6V = 12V). You can connect these systems in a series parallel configuration in order to charge or maintain 4 or more batteries in groups of 2.

As long as your batteries stay wired together they act as one large battery allowing you to charge and discharge them as a group

Battery Configurations

Model 2012 12 Volt @ 2A

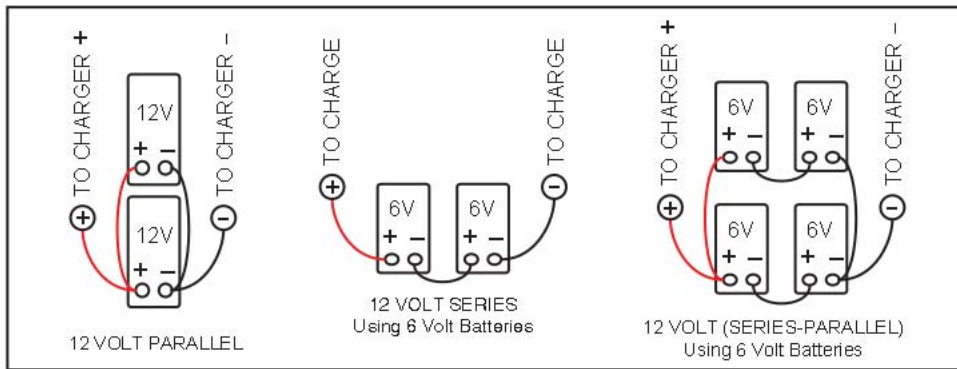

BatteryMINDER 2000 Series Charging Profile

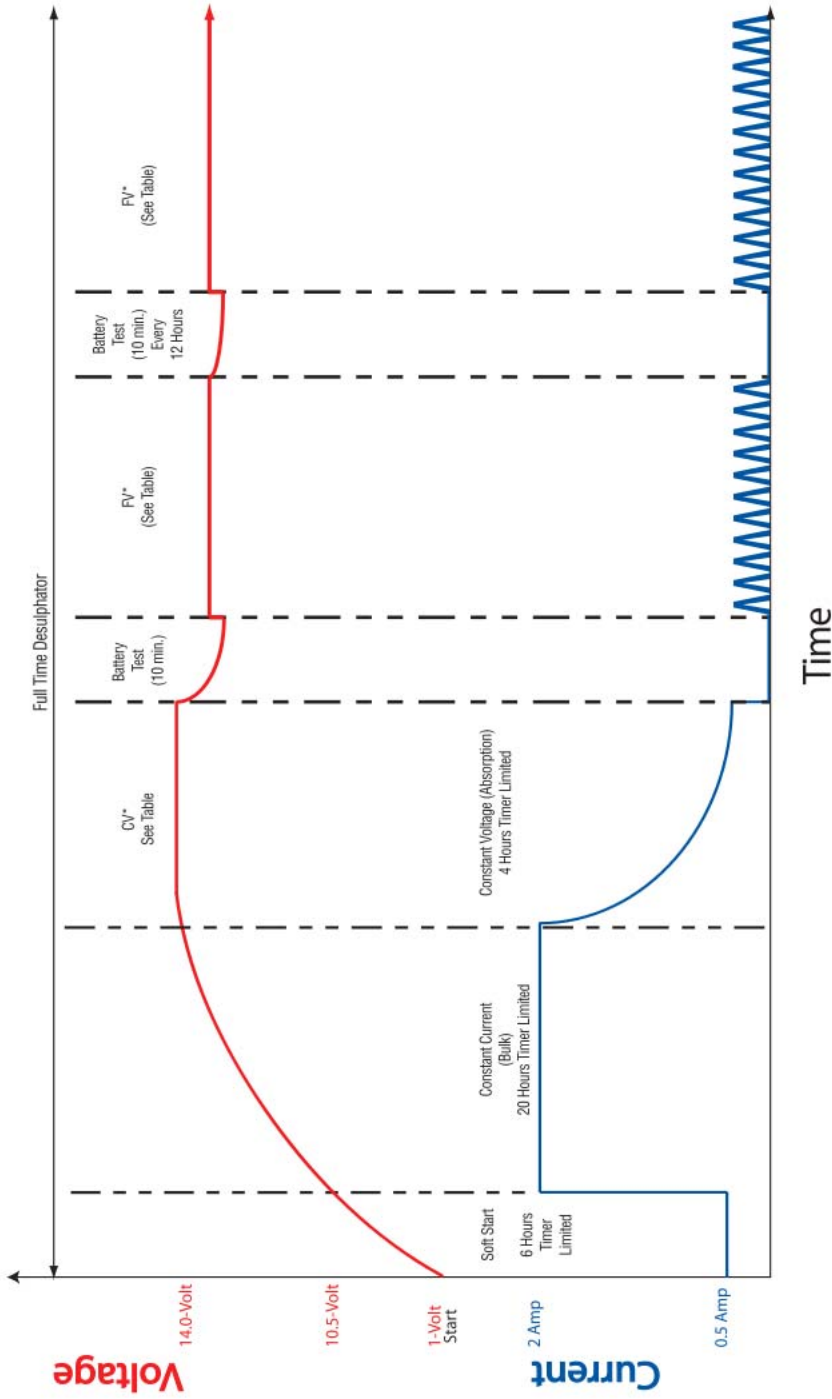

FOR REPAIR OR REPLACEMENT

All returns must be authorized by VDC Electronics.

In the event that you believe your product may be defective, you **MUST** speak to a VDC Electronics technician at **1-800-379-5579 x206** (ET) before proceeding further.

NOTES

MODEL **BatteryMINDER 20** _____

SERIAL NUMBER _____

PLACE OF PURCHASE _____

DATE OF PURCHASE _____

ALL returns must be authorized by VDC Electronics after speaking to a VDC Electronics technician at 800-379-5579 x206 (ET). Please see our “Repair or Replacement” section of this manual for additional information.

BatteryMINDER One-Year 100% Unconditional Money-Back Guarantee

This BatteryMINDER product is guaranteed to perform as claimed or WE will refund your full purchase price, including all taxes, shipping or handling cost applicable to the **purchase**.

Unit must be returned freight prepaid together with Proof of Purchase directly to VDC Electronics, Inc., NOT TO THE DEALER FROM WHICH IT WAS PURCHASED.

BatteryMINDER Five-Year Limited Warranty

VDC Electronics, Inc. warrants this product for FIVE years from date of purchase at retail against defective material or workmanship and will be repaired or replaced at no charge. We make no warranty other than this limited warranty and expressly exclude any implied warranty including any warranty for consequential damages. This limited warranty is not transferable.

Unit must be returned freight prepaid together with Proof of Purchase directly to VDC Electronics, Inc., NOT TO THE DEALER FROM WHICH IT WAS PURCHASED.

IMPORTANT NOTICE

BatteryMINDER® Five-Year Warranty Registration Reminder

Online Registration:

<http://www.batteryminders.com/register>

Please register your unit online within 10 days of purchase. **Due to the ever-changing technology associated with this BatteryMINDER® unit, we may be unable to keep you apprised of significant upgrades, changes, etc. without your registration.** The information you provide upon registration will be used to keep a record of your purchase and will assist in providing support should you ever need to contact our

Technical Service department:

techsupport@vdcelectronics.com; 800-379-5579 x206 (ET).